

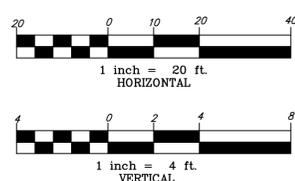



COPYRIGHT © W.K. DICKSON & COMPANY, INC. ALL RIGHTS RESERVED. THIS DRAWING IS AN INSTRUMENT OF SERVICE AND SHALL REMAIN THE PROPERTY OF W.K. DICKSON & COMPANY, INC. NO PART OF THIS DRAWING IS TO BE REPRODUCED OR TRANSMITTED IN ANY FORM OR BY ANY MEANS, ELECTRONIC OR MECHANICAL, WITHOUT THE EXPRESS WRITTEN PERMISSION OF W.K. DICKSON & COMPANY, INC.



Received  
 Dec 7, 2023  
 V-23-0019  
 Planning & Zoning

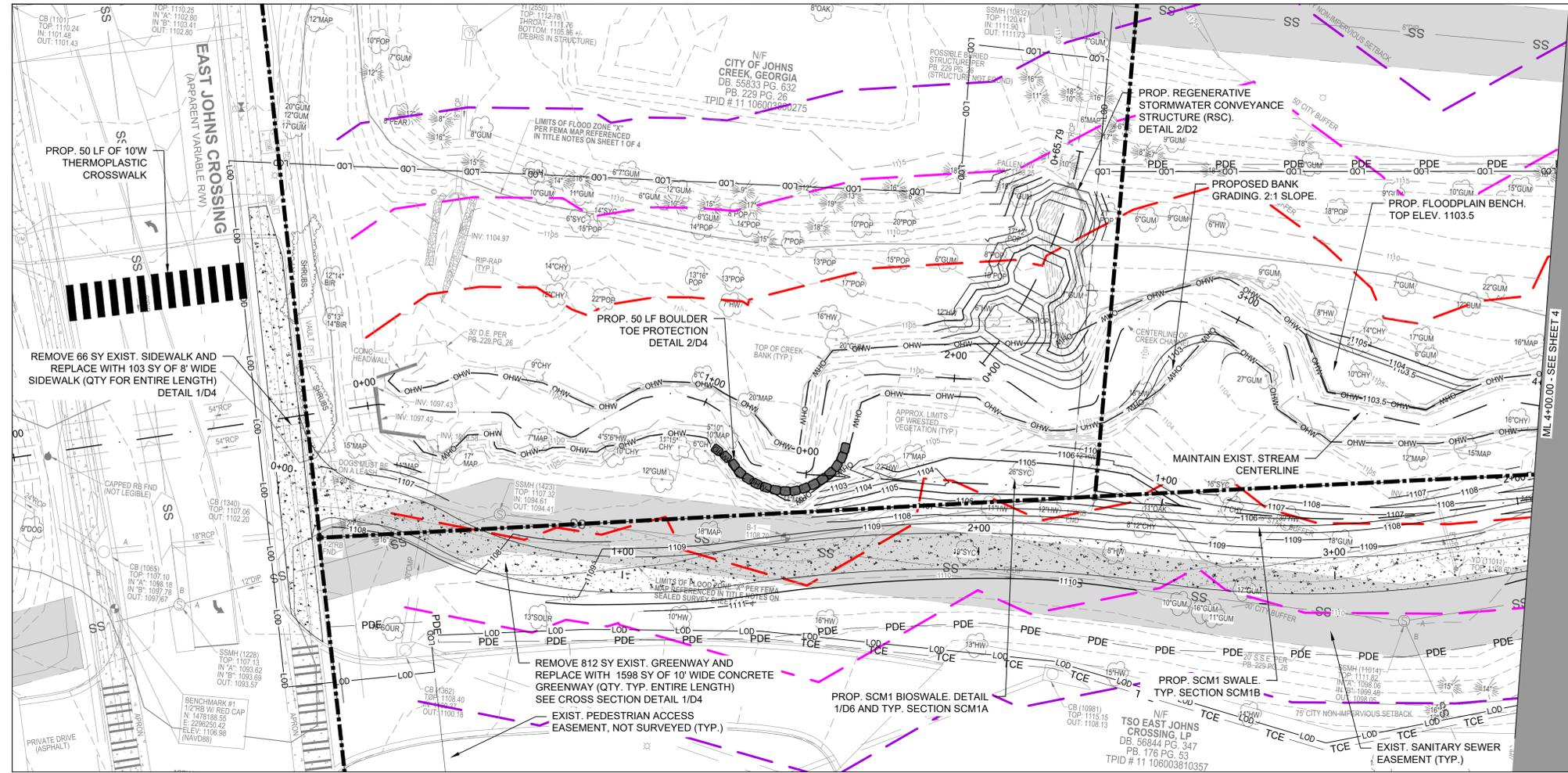

**WK DICKSON**  
 community infrastructure consultants  
 720 CORPORATE CENTER DR  
 RALEIGH, NC 27607  
 (919) 782-0495  
 WWW.WKDICKSON.COM

GEORGIA  
 W. K. DICKSON  
 & COMPANY, INC.  
 No. 9820337  
 Exp. 06/30/2024  
 STATE OF AUTHORIZATION  
 C.O.A.

PROFESSIONAL SEAL

NO.	DATE	DESCRIPTION

### ADDITIONAL LEGEND

- 25' STATE BUFFER
- 50' CITY BUFFER
- 75' CITY NON-IMPERVIOUS SETBACK

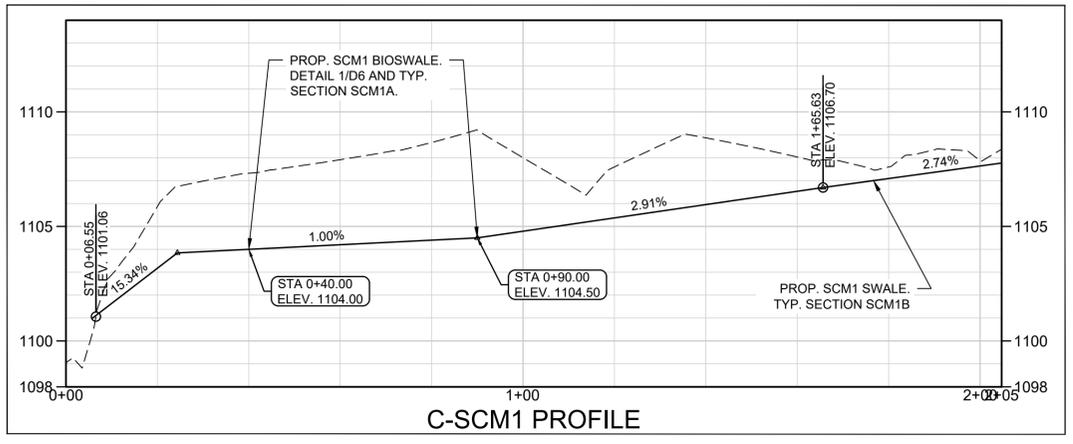
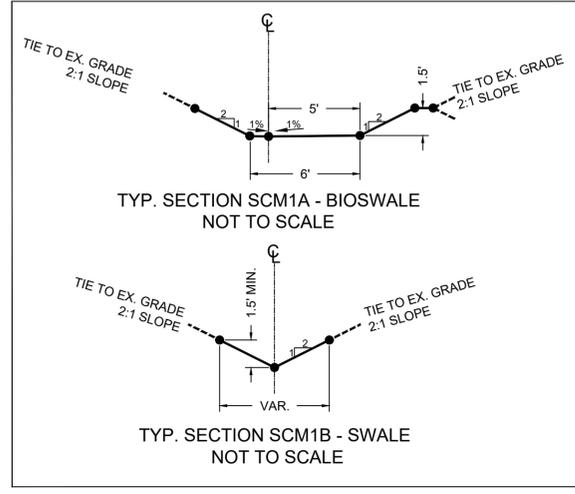
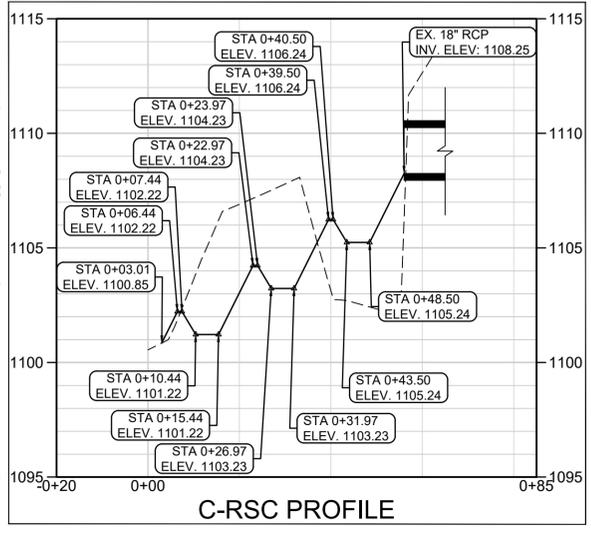
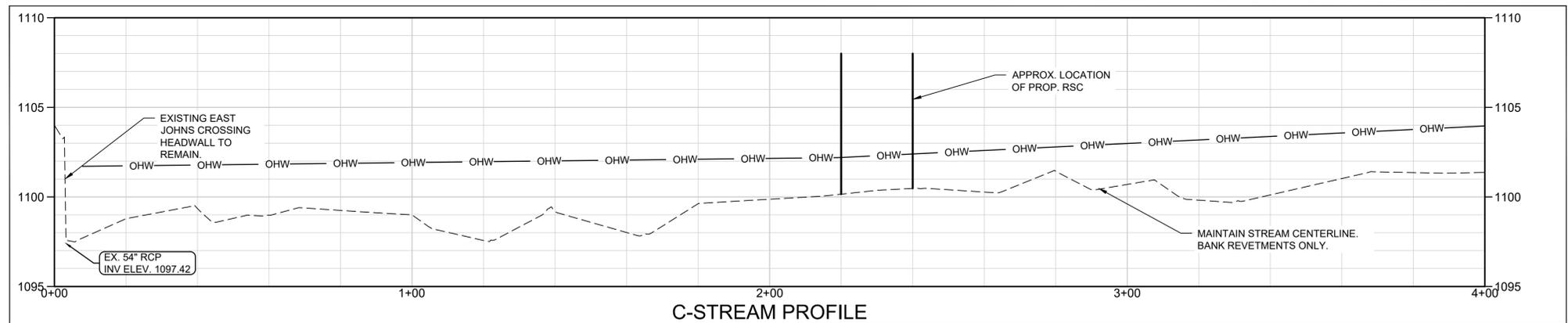

CONCEPTUAL EASEMENT EXHIBITS - FOR REVIEW ONLY

PROJECT NAME: TOWN CENTER STREAM RESTORATION DESIGN FOR CITY OF JOHNS CREEK  
 DRAWING TITLE: PLAN & PROFILE - STA 0+00 TO 4+00

PROJ. MGR.: TLM  
 DESIGN BY: LD  
 DRAWN BY: BFL  
 PROJ. DATE: OCT. 2023  
 DRAWING NUMBER: **3**  
 WKD PROJ. NO.: 20230198.01.RA

COPYRIGHT © W.K. DICKSON & COMPANY, INC. ALL RIGHTS RESERVED. THE INFORMATION CONTAINED HEREIN IS THE PROPERTY OF W.K. DICKSON & COMPANY, INC. AND SHALL REMAIN THE PROPERTY OF W.K. DICKSON & COMPANY, INC. NO PART OF THIS DOCUMENT IS TO BE REPRODUCED OR TRANSMITTED IN ANY FORM OR BY ANY MEANS, ELECTRONIC OR MECHANICAL, INCLUDING PHOTOCOPYING, RECORDING, OR BY ANY INFORMATION STORAGE AND RETRIEVAL SYSTEM, WITHOUT THE EXPRESS WRITTEN PERMISSION OF W.K. DICKSON & COMPANY, INC.

- NOTES:
- SEE SHEET 7 FOR REPRESENTATIVE CROSS SECTIONS.

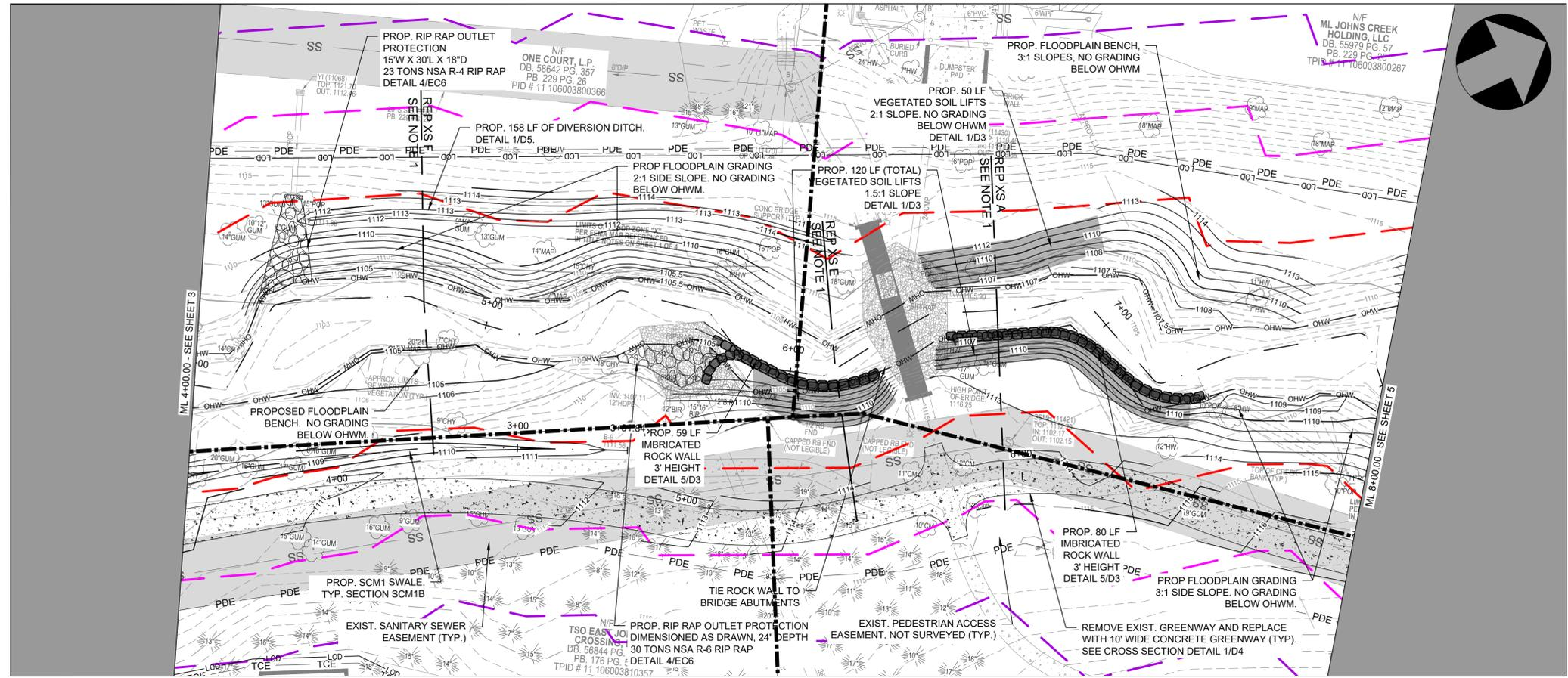

### ADDITIONAL LEGEND

- 25' STATE BUFFER
- 50' CITY BUFFER
- 75' CITY NON-IMPERVIOUS SETBACK

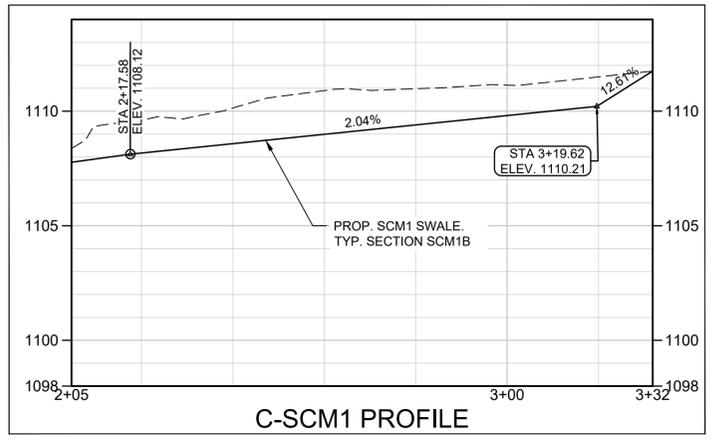
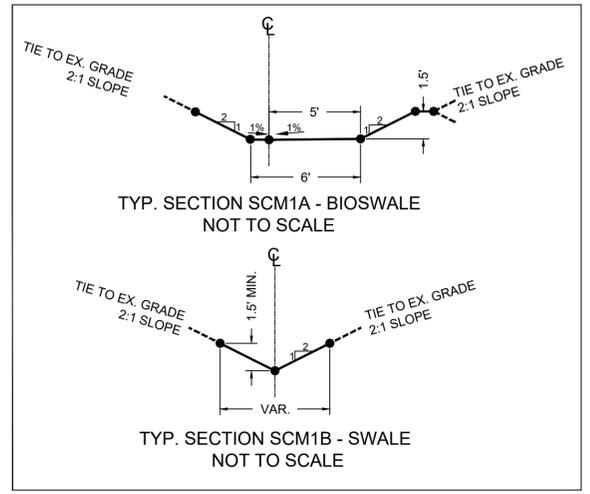
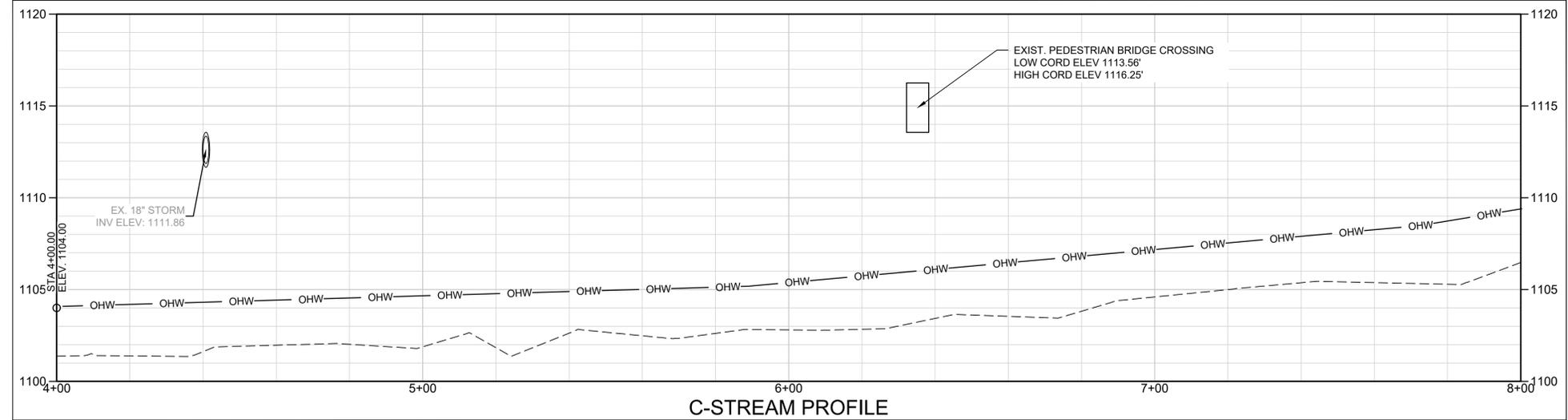

Received  
 Dec 7, 2023  
 V-23-0019  
 Planning & Zoning

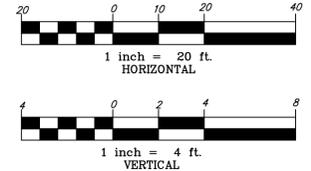

**WK DICKSON**  
 community infrastructure consultants  
 720 CORPORATE CENTER DR  
 RALEIGH, NC 27607  
 (919) 782-0495  
 WWW.WKDICKSON.COM

GEORGIA  
 W. K. DICKSON & COMPANY, INC.  
 No. 9820207  
 EXP. 06/30/2024  
 STATE OF AUTOMATIC RENEWAL  
 C.O.A.

PROFESSIONAL SEAL

NO.	DATE	DESCRIPTION	BY

PROJECT NAME:  
 TOWN CENTER STREAM RESTORATION DESIGN FOR CITY OF JOHNS CREEK  
 DRAWING TITLE:  
 PLAN & PROFILE - STA 4+00 TO 8+00

PROJ. MGR.: TLM  
 DESIGN BY: LD  
 DRAWN BY: BFL  
 PROJ. DATE: OCT. 2023  
 DRAWING NUMBER:  
**4**  
 WKD PROJ. NO.:  
 20230198.01.RA

CONCEPTUAL EASEMENT EXHIBITS - FOR REVIEW ONLY



COPYRIGHT © W.K. DICKSON & COMPANY, INC. ALL RIGHTS RESERVED. THE INFORMATION CONTAINED HEREIN IS THE PROPERTY OF W.K. DICKSON & COMPANY, INC. AND SHALL REMAIN THE PROPERTY OF W.K. DICKSON & COMPANY, INC. NO PART OF THIS DOCUMENT IS TO BE REPRODUCED OR TRANSMITTED IN ANY FORM OR BY ANY MEANS, ELECTRONIC OR MECHANICAL, INCLUDING PHOTOCOPYING, RECORDING, OR BY ANY INFORMATION STORAGE AND RETRIEVAL SYSTEM, WITHOUT THE EXPRESS WRITTEN PERMISSION OF W.K. DICKSON & COMPANY, INC.

NOTES:  
 1. SEE SHEET 7 FOR REPRESENTATIVE CROSS SECTIONS.

### ADDITIONAL LEGEND

- 25' STATE BUFFER
- 50' CITY BUFFER
- 75' CITY NON-IMPERVIOUS SETBACK

PARCEL #11 106003800101  
 CROSS CREEK RETAIL PARTNERS, LTD.  
 NOTE: PROPOSED WORK WITHIN THIS  
 PARCEL NOT INCLUDED IN THE CITY  
 BUFFER VARIANCE APPLICATION DATED  
 12-08-2023.

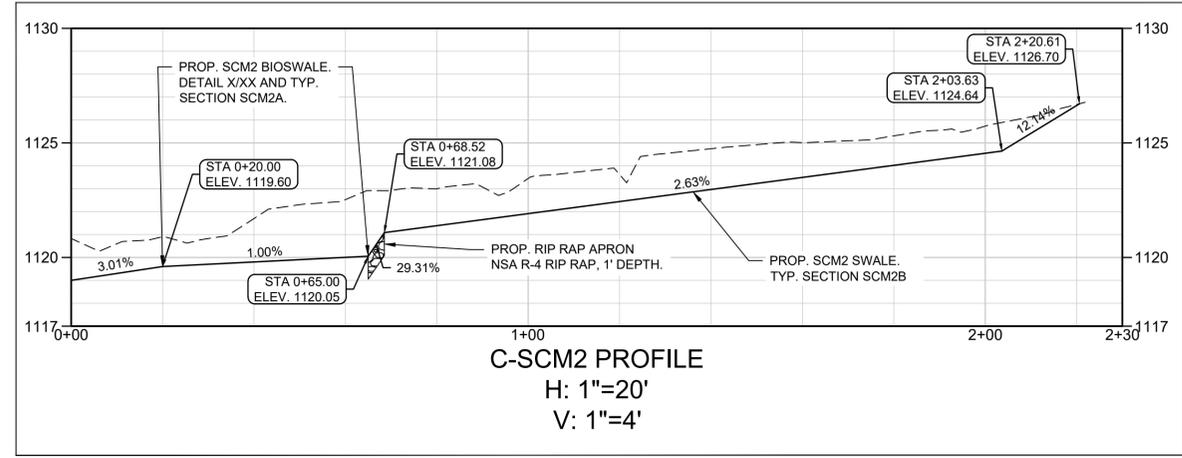
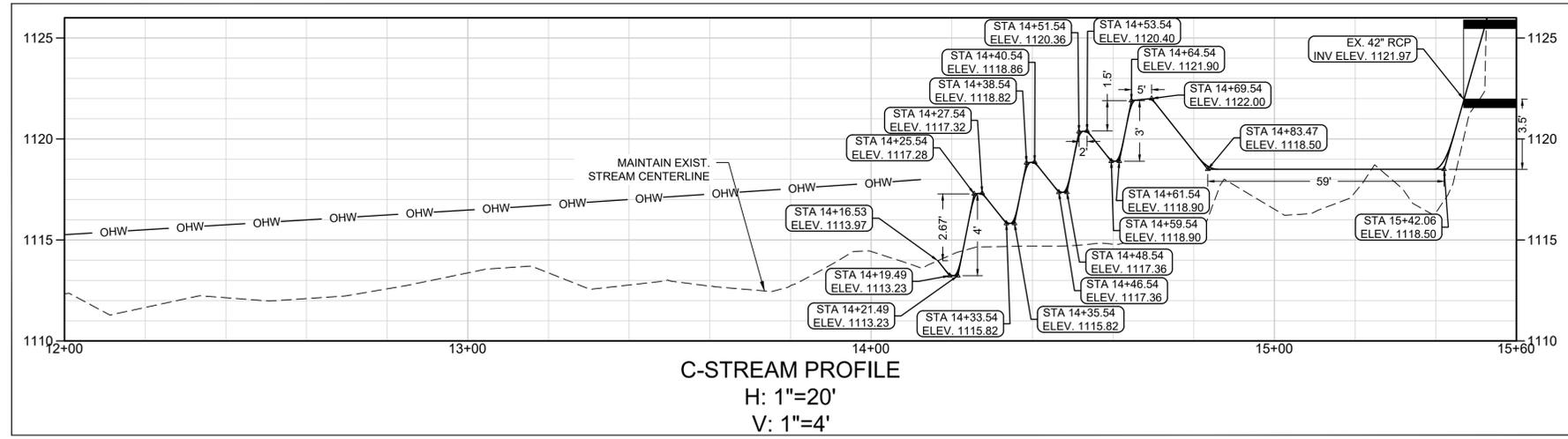
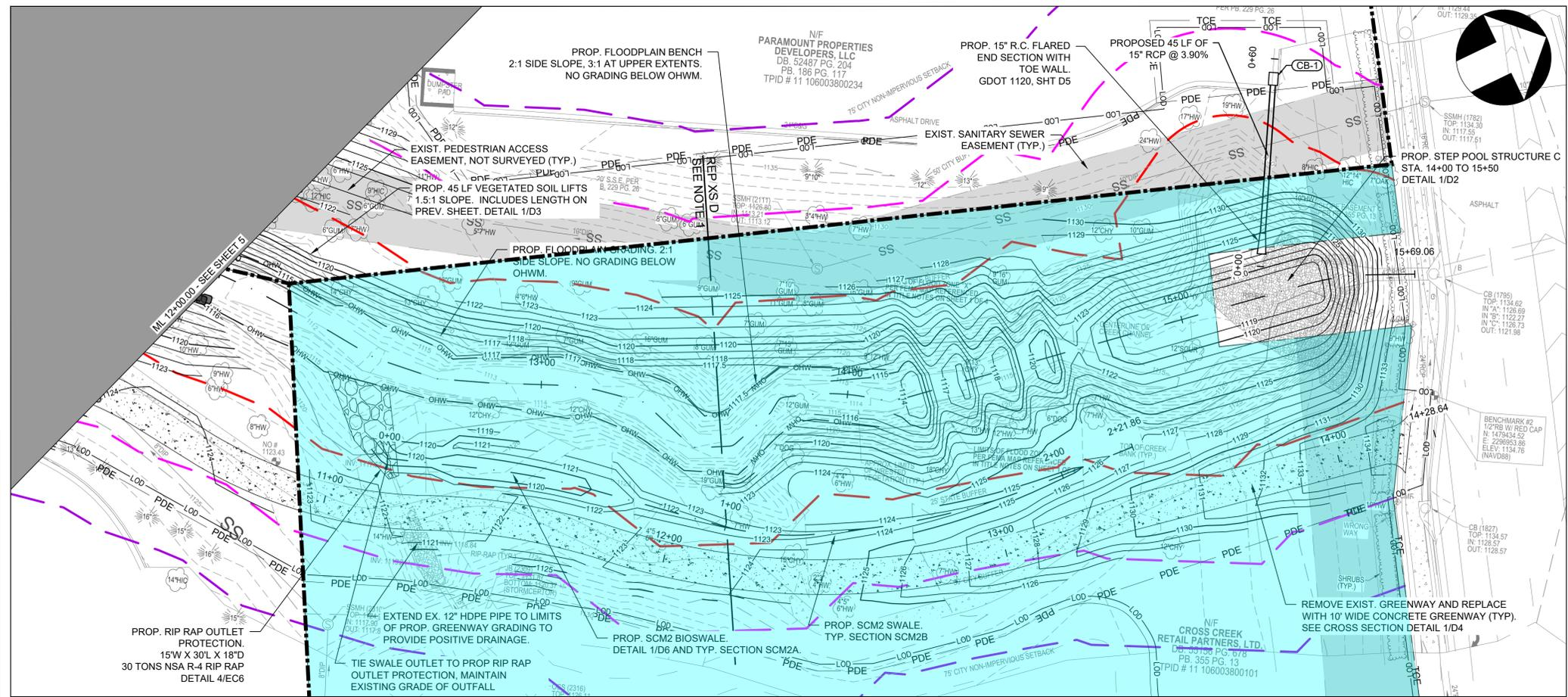
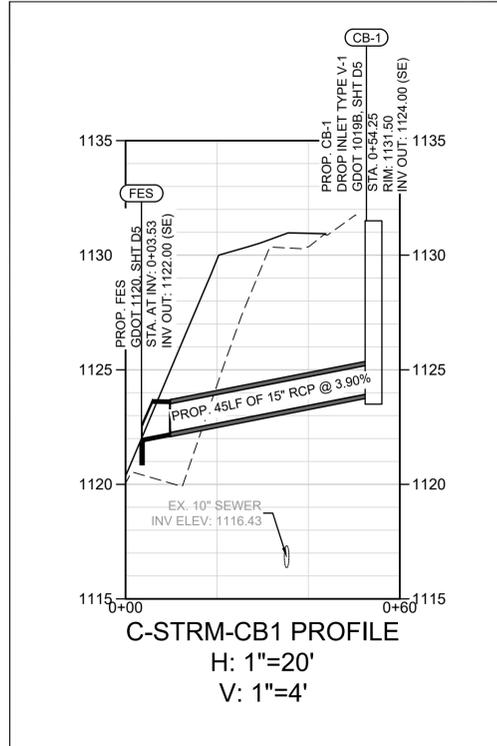
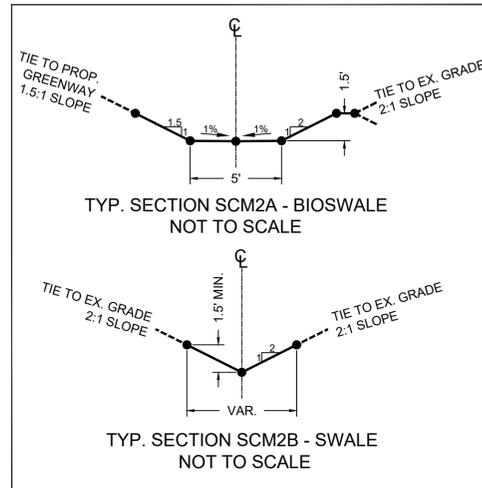

Received  
 Dec 7, 2023  
 V-23-0019  
 Planning & Zoning

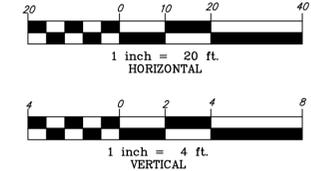

**WK DICKSON**  
 community infrastructure consultants  
 720 CORPORATE CENTER DR  
 RALEIGH, NC 27607  
 (919) 782-0495  
 WWW.WKDICKSON.COM

GEORGIA  
 W. K. DICKSON & COMPANY, INC.  
 PROFESSIONAL SEAL  
 C.O.A.

PROFESSIONAL SEAL

NO.	DATE	DESCRIPTION	BY

PROJECT NAME: TOWN CENTER STREAM RESTORATION DESIGN FOR CITY OF JOHNS CREEK  
 DRAWING TITLE: PLAN & PROFILE - STA 12+00 TO 15+60

PROJ. MGR.: TLM  
 DESIGN BY: LD  
 DRAWN BY: BFL  
 PROJ. DATE: OCT. 2023  
 DRAWING NUMBER:  
**6**  
 WKD PROJ. NO.: 20230198.01.RA

CONCEPTUAL EASEMENT EXHIBITS - FOR REVIEW ONLY

FILE PATH: Z:\Projects\Johns Creek Stream Design\CAD\DWG\150230198\_01.PLT





















COPYRIGHT © W. K. DICKSON & COMPANY, INC. ALL RIGHTS RESERVED. THE INFORMATION CONTAINED HEREIN IS THE PROPERTY OF W. K. DICKSON & COMPANY, INC. AND SHALL REMAIN THE PROPERTY OF W. K. DICKSON & COMPANY, INC. ANY REPRODUCTION OR TRANSMISSION OF THIS INFORMATION WITHOUT THE EXPRESS WRITTEN PERMISSION OF W. K. DICKSON & COMPANY, INC. IS PROHIBITED.

**Ss**

**Sb**

**1 BANK STABILIZATION DETAIL**  
NOT TO SCALE

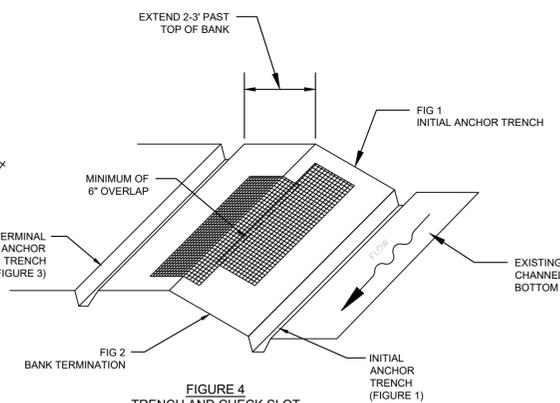
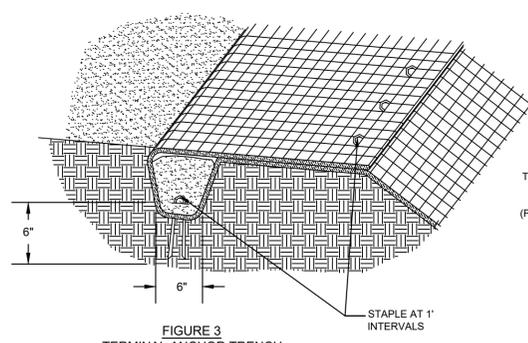
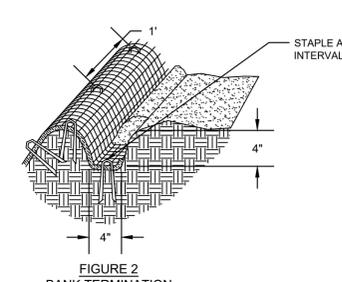
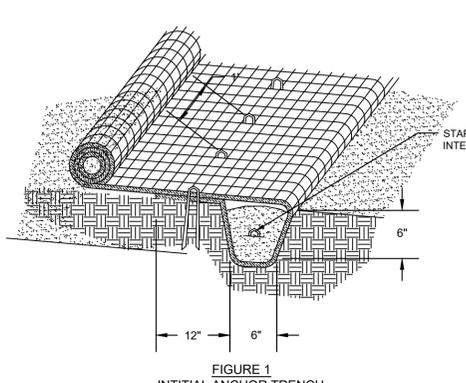
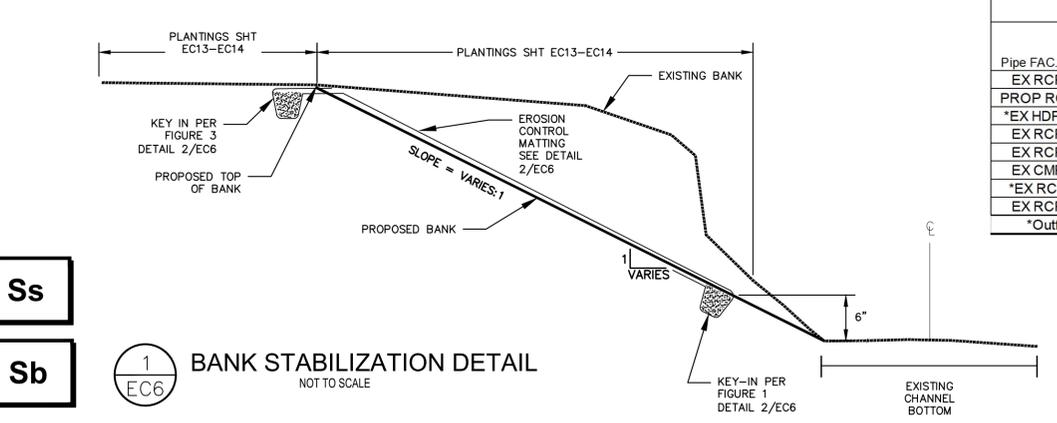

**INSTALLATION NOTES:**

EROSION CONTROL MATTING SHALL BE A 100% STRAW MULCH ENCASED IN A MEDIUM WEIGHT PLASTIC NETTING (BOTH SIDES) WITH A MINIMUM PERMISSIBLE SHEAR STRESS OF 1.75 LBS PER SQ. FT.

**SITE PREPARATION**  
GRADE AND COMPACT AREA.  
REMOVE ALL ROCKS, CLODS, VEGETATION, AND OBSTRUCTIONS SO THAT MATTING WILL HAVE DIRECT CONTACT WITH THE SOIL.  
PREPARE SEEDBED BY LOOSENING 3 TO 4 INCHES OF TOPSOIL ABOVE FINAL GRADE.  
APPLY ANY TREATMENT SUCH AS LIME OR FERTILIZERS TO THE SOIL IF NEEDED.  
**DO NOT** MULCH AREAS WHERE MAT IS TO BE INSTALLED.

**SEEDING**  
SEE EROSION CONTROL SHEETS FOR SEEDING REQUIREMENTS.  
APPLY SEED TO SOIL BEFORE PLACING MATTING.

**INSTALLATION ON BANKS**

EXTEND MAT 2 TO 3 FEET OVER CREST OF SLOPE AND EXCAVATE A 6" x 6" TERMINAL ANCHOR TRENCH. SEE FIGURE 4.  
ANCHOR MAT IN TRENCH ON 1 FOOT SPACINGS, BACKFILL AND COMPACT SOIL.  
OVERLAP ADJACENT MATS 6" AND ANCHOR EVERY 18" ACROSS THE OVERLAP. THE HIGHER ELEVATION MAT SHOULD BE PLACED OVER THE LOWER ELEVATION MAT.  
EDGES SHOULD BE SHINGLED AWAY FROM THE FLOW OF WATER.  
LAY MAT LOOSE TO ALLOW CONTACT WITH SOIL. **DO NOT** STRETCH TIGHT.  
ANCHOR MAT USING U-SHAPED WIRE STAPLES OR GEOTEXTILE PINS.

**EROSION CONTROL MATTING INSTALLATION**  
NOT TO SCALE

**Ss**

**2 EC6**

**St CHART (STORM DRAIN OUTLET PROTECTION)**

Pipe FAC. ID	STA.	Effective Pipe Dia (in)	Q (cfs)	V (fps)	La (ft)	D (ft)	W1 (ft)	W2 (ft)	d50 (ft)	tailwater
EX RCP	15+50	42"	122	12.7	PLUNGE POOL DIMENSIONED AS DRAWN	DET 1/D2				MINIMUM
PROP RCP	15+30	15"	3.86	3.2	PLUNGE POOL DIMENSIONED AS DRAWN	DET 1/D2				MINIMUM
*EX HDPE	12+50	12"	9	11.5	30.0	1.5	3.0	15.0	0.5	MAXIMUM
EX RCP	11+75	36"	27.2	3.8	STEP POOL DIMENSIONED AS SHOWN				0.7	MINIMUM
EX RCP	9+50	18"	23.7	13.5	STEP POOL DIMENSIONED AS SHOWN				0.5	MINIMUM
EX CMP	5+50	36"	36	5.1	DIMENSIONED AS SHOWN				1.0	MINIMUM
*EX RCP	4+30	18"	15	8.6	30.0	1.5	5.0	15.0	0.5	MAXIMUM
EX RCP	2+20	24"	34.8	11.0	RSC DESIGN TO BE DEVELOPED					

\*Outfall denoted with asterisk modeled as pipe flowing full because pipe capacity was smaller than 25-yr flow.

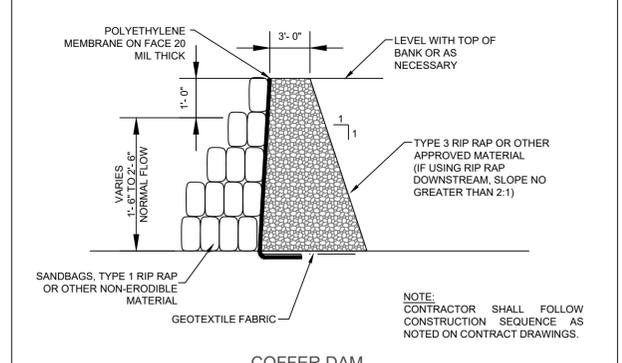
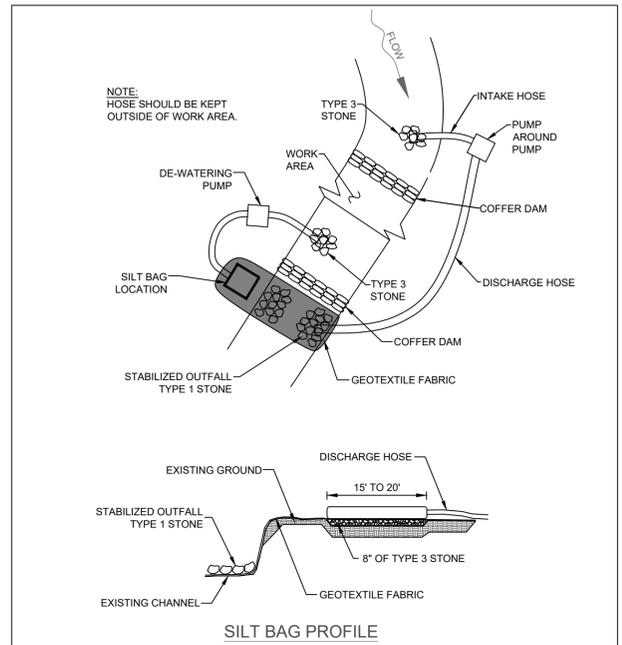

- NOTES:**
- EXCAVATION SHALL BE PERFORMED ONLY IN DRY AND/OR ISOLATED SECTIONS OF CHANNEL.
  - COFFER DAMS SHOULD BE USED TO ISOLATE WORK AREAS FROM STREAM FLOW.
  - THE CONTRACTOR SHALL NOT DISTURB MORE AREA THAN CAN BE STABILIZED IN ONE WORKING DAY.
  - THE PUMP-AROUND PUMP SHOULD ADEQUATELY CONVEY A MINIMUM 1,200 GALLONS / MINUTE.
  - PERFORMANCE Q=1,200 GPM ONLY.
  - COFFER DAM MUST BE CONSTRUCTED OF NON-ERODIBLE MATERIALS SUCH AS SANDBAGS.
- SEQUENCE OF CONSTRUCTION FOR TYPICAL PUMP AROUND**
- INSTALL STILLING BASIN AND STABILIZED OUTFALL USING CLASS A RIP RAP AT THE DOWNSTREAM END OF THE DESIGNATED PROJECT WORKING AREA.
  - THE CONTRACTOR WILL INSTALL THE PUMP AROUND PUMP AND THE TEMPORARY PIPING THAT WILL CONVEY THE BASE FLOW FROM UPSTREAM OF THE WORK AREA TO THE STABILIZED OUTFALL.
  - INSTALL UPSTREAM COFFER DAM AND BEGIN PUMPING OPERATIONS FOR STREAM DIVERSION.
  - INSTALL THE DOWNSTREAM COFFER DAM AND DEWATERING PUMPING APPARATUS IF NEEDED TO DEWATER THE ENTRAPPED AREA. THE PUMP AND HOSE FOR THIS PURPOSE SHALL BE OF SUFFICIENT SIZE TO DEWATER THE WORK AREA. THIS WATER WILL ALSO BE PUMPED TO AN OUTFALL STABILIZED WITH CLASS A RIP RAP.
  - THE CONTRACTOR WILL PERFORM CHANNEL WORK IN ACCORDANCE WITH THE PLAN AND FOLLOWING THE GENERAL CONSTRUCTION SEQUENCE.
  - THE CONTRACTOR WILL EXCAVATE ANY ACCUMULATED SILT AND DEWATER BEFORE REMOVAL OF THE COFFER DAM. WHEN DEWATERING THE AREA, ALL DIRTY WATER MUST BE PUMPED THROUGH A SILT BAG. REMOVE COFFER DAMS, PUMPS, AND TEMPORARY FLEXIBLE HOSE/PIPING STARTING WITH THE DOWNSTREAM COFFER DAM FIRST.
  - ONCE THE WORKING AREA IS COMPLETED, REMOVE ALL RIP RAP AND COFFER DAMS AND STABILIZE DISTURBED AREAS WITH SEED AND MULCH.
  - ALL WORK IN CHANNEL MUST BE COMPLETED BEFORE REMOVING COFFER DAMS.

**3 PUMP AROUND**  
NOT TO SCALE

**3 EC6**

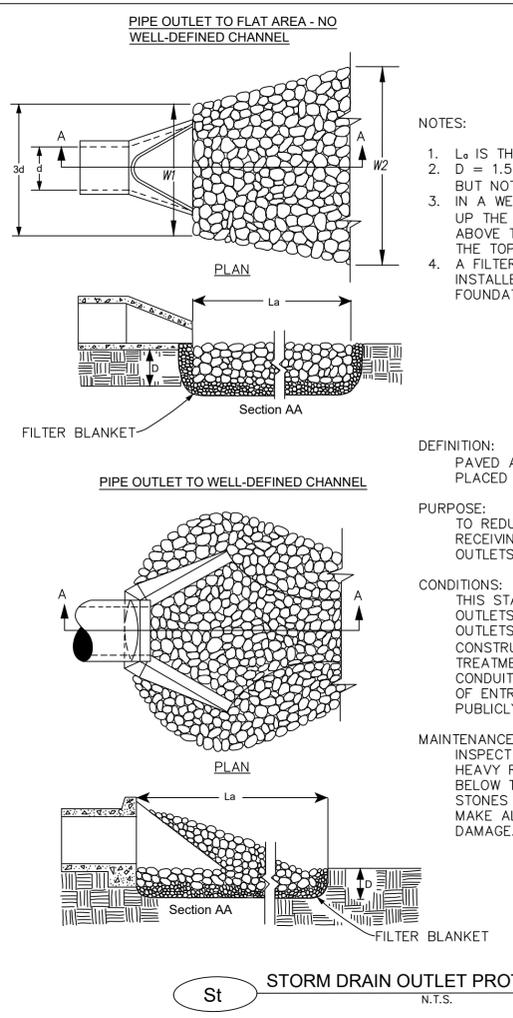

**4 STORM DRAIN OUTLET PROTECTION**  
NOT TO SCALE

**4 EC6**

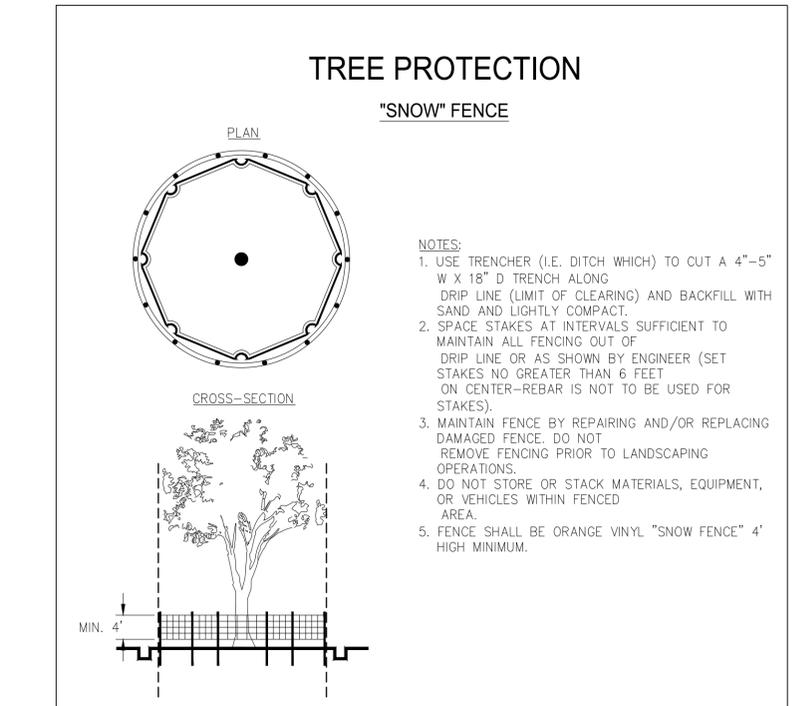

**TREE PROTECTION**  
"SNOW" FENCE

- NOTES:**
- USE TRENCHER (I.E. DITCH WHICH) TO CUT A 4"-5" W X 18" D TRENCH ALONG DRIP LINE (LIMIT OF CLEARING) AND BACKFILL WITH SAND AND LIGHTLY COMPACT.
  - SPACE STAKES AT INTERVALS SUFFICIENT TO MAINTAIN ALL FENCING OUT OF DRIP LINE OR AS SHOWN BY ENGINEER (SET STAKES NO GREATER THAN 6 FEET ON CENTER-REBAR IS NOT TO BE USED FOR STAKES).
  - MAINTAIN FENCE BY REPAIRING AND/OR REPLACING DAMAGED FENCE. DO NOT REMOVE FENCING PRIOR TO LANDSCAPING OPERATIONS.
  - DO NOT STORE OR STACK MATERIALS, EQUIPMENT, OR VEHICLES WITHIN FENCED AREA.
  - FENCE SHALL BE ORANGE VINYL "SNOW FENCE" 4' HIGH MINIMUM.

**WK DICKSON**  
community infrastructure consultants  
720 CORPORATE CENTER DR  
RALEIGH, NC 27607  
(919)782-0495  
WWW.WKDICKSON.COM

GEORGIA  
W. K. DICKSON & COMPANY, INC.  
EX. 06/03/2024  
STATE OF AUT. REGISTRATION  
C.O.A.

PROFESSIONAL SEAL

NO.	REVISION RECORD	DESCRIPTION	DATE	BY

PROJECT NAME: TOWN CENTER STREAM RESTORATION DESIGN FOR CITY OF JOHNS CREEK  
DRAWING TITLE: EC DETAILS

PROJ. MGR.: TLM  
DESIGN BY: LD  
DRAWN BY: BFL  
PROJ. DATE: OCT. 2023  
DRAWING NUMBER: **EC6**  
WKD PROJ. NO.: 20230198.01.RA

PERMITTING SET - FOR REVIEW ONLY

Copyright © W.K. Dickson & Company, Inc. All rights reserved. This drawing is a preliminary design and shall remain the property of W.K. Dickson & Company, Inc. No part of this drawing may be reproduced or transmitted in any form or by any means, electronic or mechanical, including photocopying, recording, or by any information storage and retrieval system, without the prior written permission of W.K. Dickson & Company, Inc.

Received  
Dec 7, 2023  
V-23-0019  
Planning & Zoning

### ADDITIONAL LEGEND

- 25' STATE BUFFER
- 50' CITY BUFFER
- 75' CITY NON-IMPERVIOUS SETBACK
- LIMITS OF DISTURBANCE
- SEDIMENT FENCE (SILT FENCE)
- CONSTRUCTION STAGING AREA
- CONCRETE WASHOUT DEVICE
- TREE REMOVAL
- TREE PROTECTION

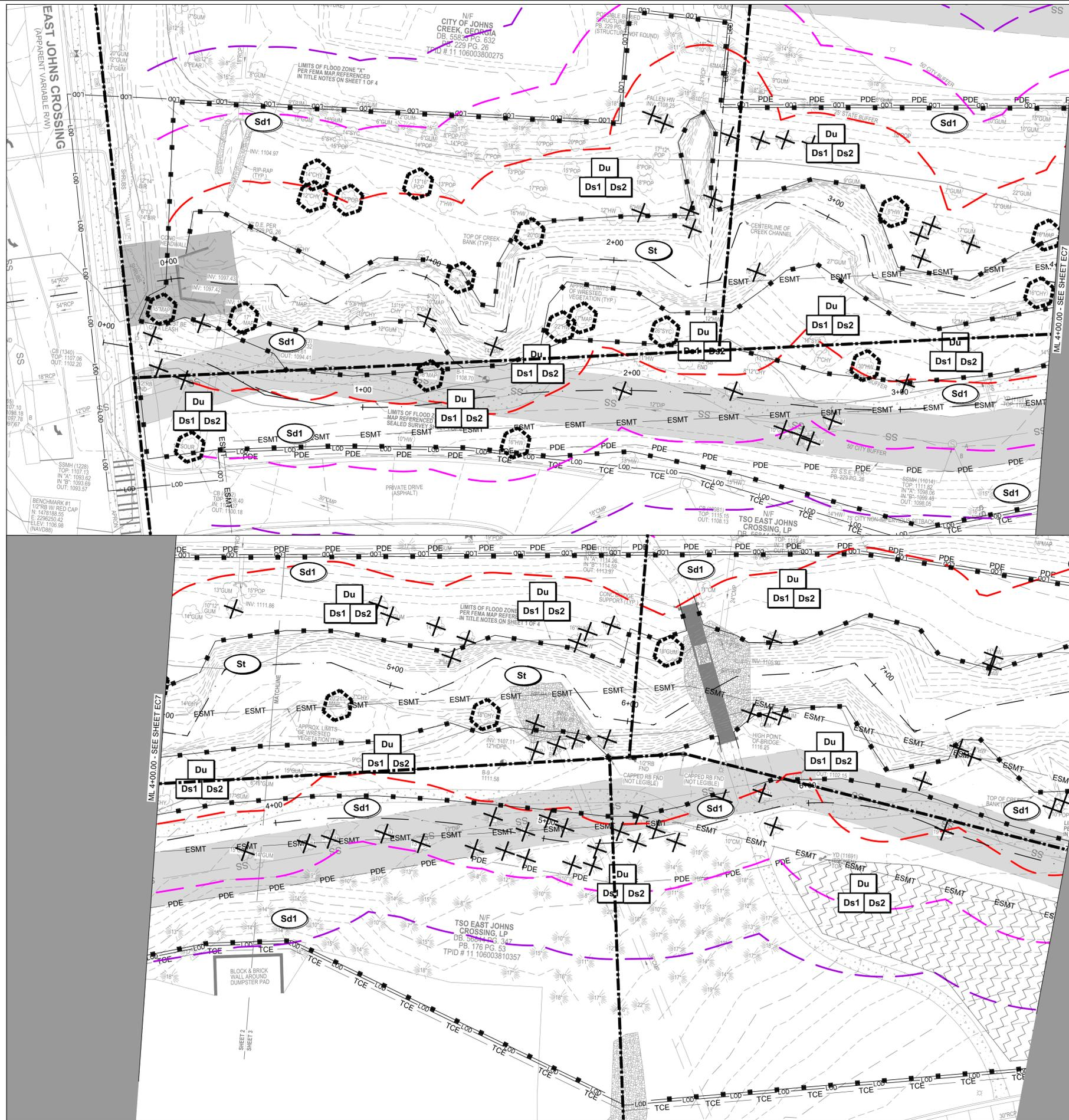
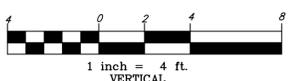

**WK DICKSON**  
community infrastructure consultants  
720 CORPORATE CENTER DR  
RALEIGH, NC 27607  
(919) 782-0495  
WWW.WKDICKSON.COM

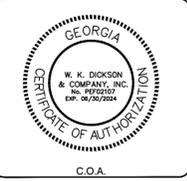

PROFESSIONAL SEAL

NO.	DATE	DESCRIPTION

PROJECT NAME: TOWN CENTER STREAM RESTORATION DESIGN FOR CITY OF JOHNS CREEK  
DRAWING TITLE: INITIAL EC PLAN - STA 0+00 TO 8+00

PROJ. MGR.: TLM  
DESIGN BY: LD  
DRAWN BY: BFL  
PROJ. DATE: OCT. 2023  
DRAWING NUMBER: **EC7**  
WKD PROJ. NO.: 20230198.01.RA

PERMITTING SET - FOR REVIEW ONLY



COPYRIGHT © W.K. DICKSON & COMPANY, INC. ALL RIGHTS RESERVED. THE INFORMATION CONTAINED HEREIN IS THE PROPERTY OF W.K. DICKSON & COMPANY, INC. AND SHALL REMAIN THE PROPERTY OF W.K. DICKSON & COMPANY, INC. NO PART OF THIS DOCUMENT IS TO BE REPRODUCED OR TRANSMITTED IN ANY FORM OR BY ANY MEANS, ELECTRONIC OR MECHANICAL, INCLUDING PHOTOCOPYING, RECORDING, OR BY ANY INFORMATION STORAGE AND RETRIEVAL SYSTEM, WITHOUT THE EXPRESS WRITTEN PERMISSION OF W.K. DICKSON & COMPANY, INC.

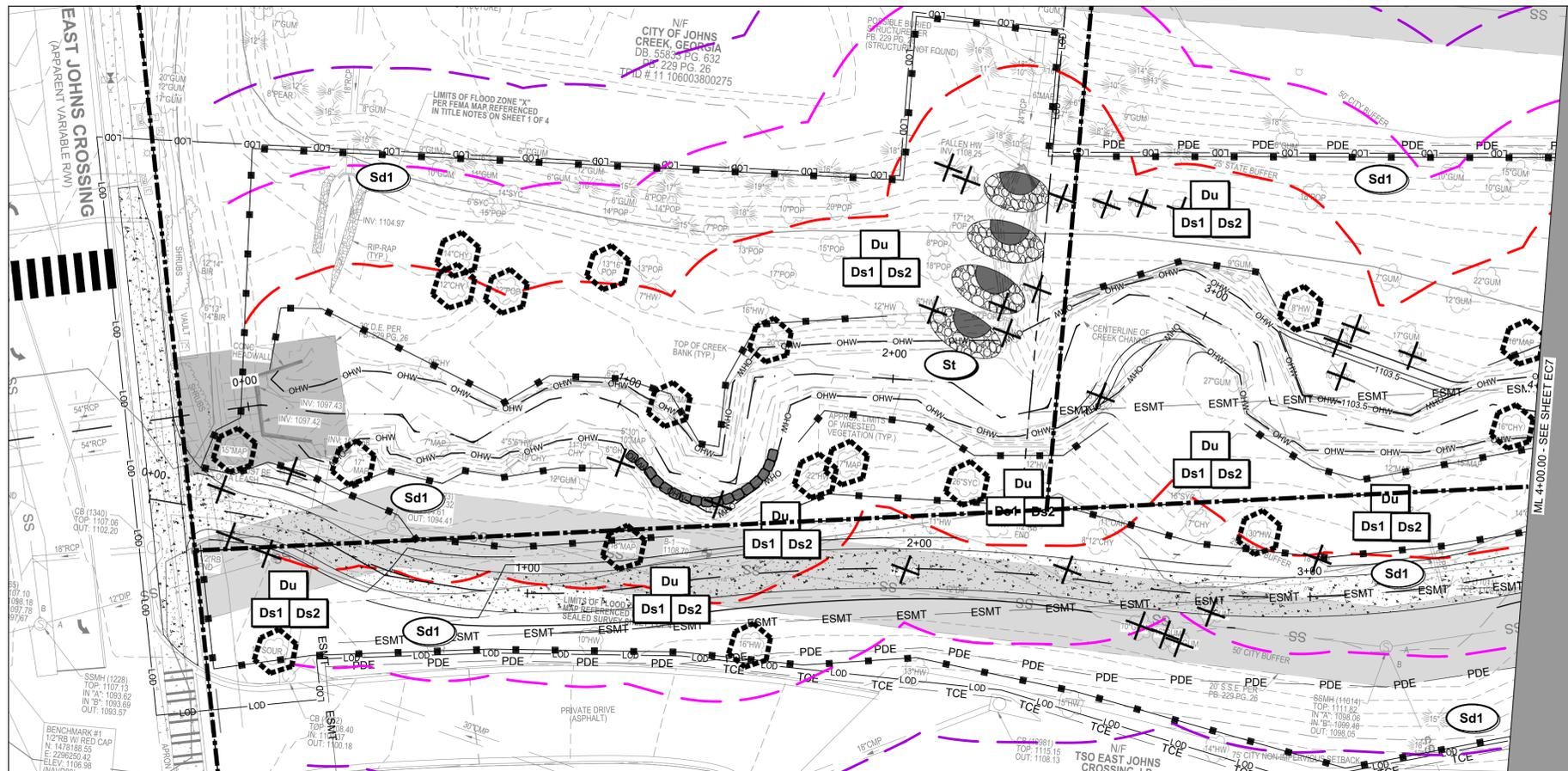

Received  
 Dec 7, 2023  
 V-23-0019  
 Planning & Zoning

### ADDITIONAL LEGEND

- 25' STATE BUFFER
- 50' CITY BUFFER
- 75' CITY NON-IMPERVIOUS SETBACK
- LOD
- LIMITS OF DISTURBANCE
- SEDIMENT FENCE (SILT FENCE)
- CONSTRUCTION STAGING AREA
- CW CONCRETE WASHOUT DEVICE
- X TREE REMOVAL
- TREE PROTECTION

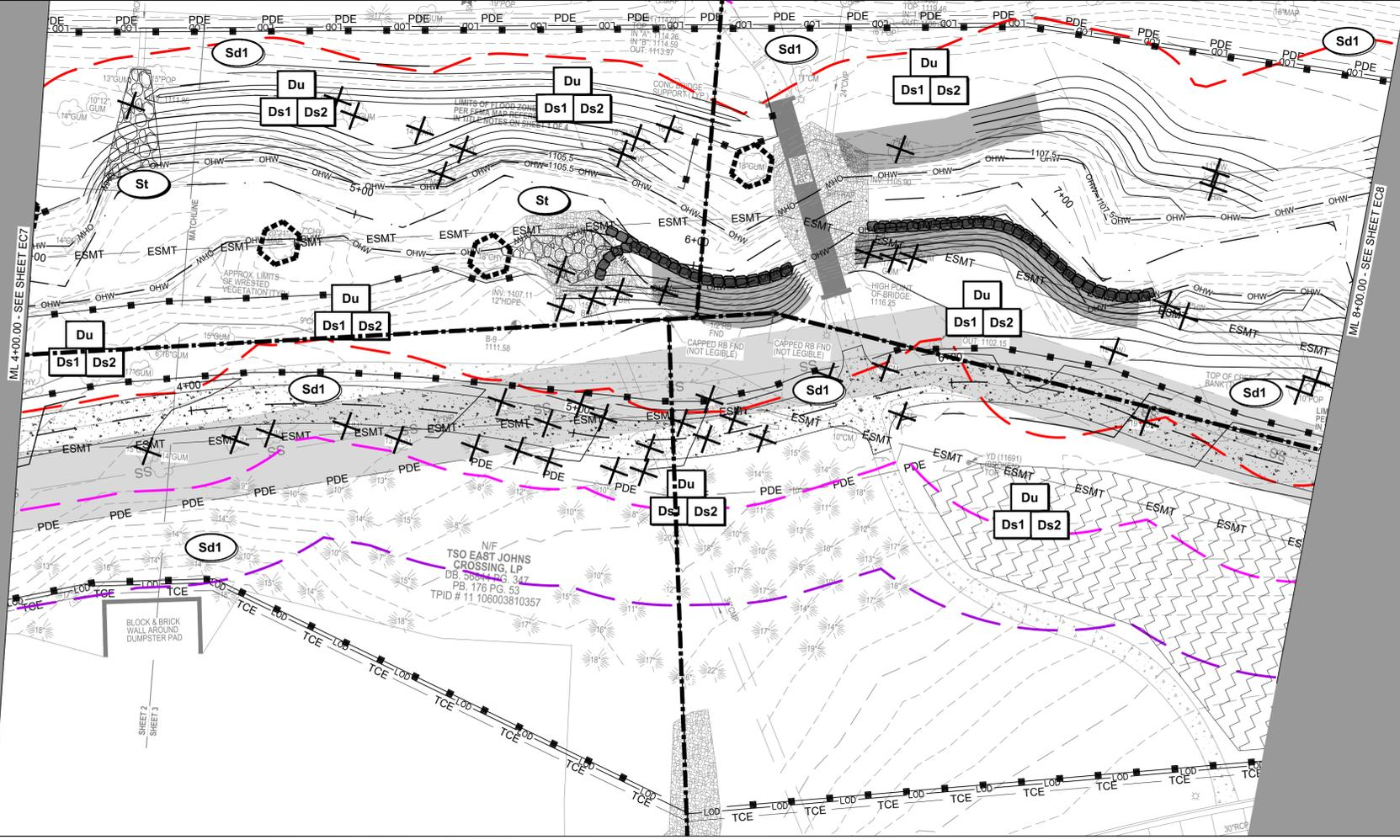
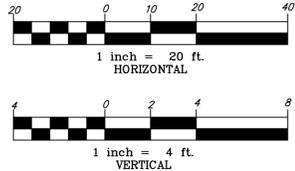

**WK DICKSON**  
 community infrastructure consultants  
 720 CORPORATE CENTER DR  
 RALEIGH, NC 27607  
 (919) 782-0495  
 WWW.WKDICKSON.COM



PROFESSIONAL SEAL

NO.	DATE	BY	DESCRIPTION

PROJECT NAME: TOWN CENTER STREAM RESTORATION DESIGN FOR CITY OF JOHNS CREEK  
 DRAWING TITLE: INTERMEDIATE EC PLAN - STA 0+00 TO 8+00

PROJ. MGR.: TLM  
 DESIGN BY: LD  
 DRAWN BY: BFL  
 PROJ. DATE: OCT. 2023  
 DRAWING NUMBER:  
EC9  
 WKD PROJ. NO.: 20230198.01.RA

PERMITTING SET - FOR REVIEW ONLY



COPYRIGHT © W.K. DICKSON & COMPANY, INC. ALL RIGHTS RESERVED. THIS DRAWING IS AN INSTRUMENT OF SERVICE AND SHALL REMAIN THE PROPERTY OF W.K. DICKSON & COMPANY, INC. NO PART OF THIS DRAWING IS TO BE REPRODUCED OR TRANSMITTED IN ANY FORM OR BY ANY MEANS, ELECTRONIC OR MECHANICAL, WITHOUT THE EXPRESS WRITTEN PERMISSION OF W.K. DICKSON & COMPANY, INC.

**WK DICKSON**  
 community infrastructure consultants  
 720 CORPORATE CENTER DR  
 RALEIGH, NC 27607  
 (919) 782-0495  
 WWW.WKDICKSON.COM



PROFESSIONAL SEAL  
 REVISION RECORD

NO.	DATE	DESCRIPTION	BY

PROJECT NAME: TOWN CENTER STREAM RESTORATION DESIGN FOR CITY OF JOHNS CREEK  
 DRAWING TITLE: FINAL EC PLAN - STA 0+00 TO 8+00

PROJ. MGR.: TLM  
 DESIGN BY: LD  
 DRAWN BY: BFL  
 PROJ. DATE: OCT. 2023  
 DRAWING NUMBER: EC11  
 WKD PROJ. NO.: 20230198.01.RA

PERMITTING SET - FOR REVIEW ONLY

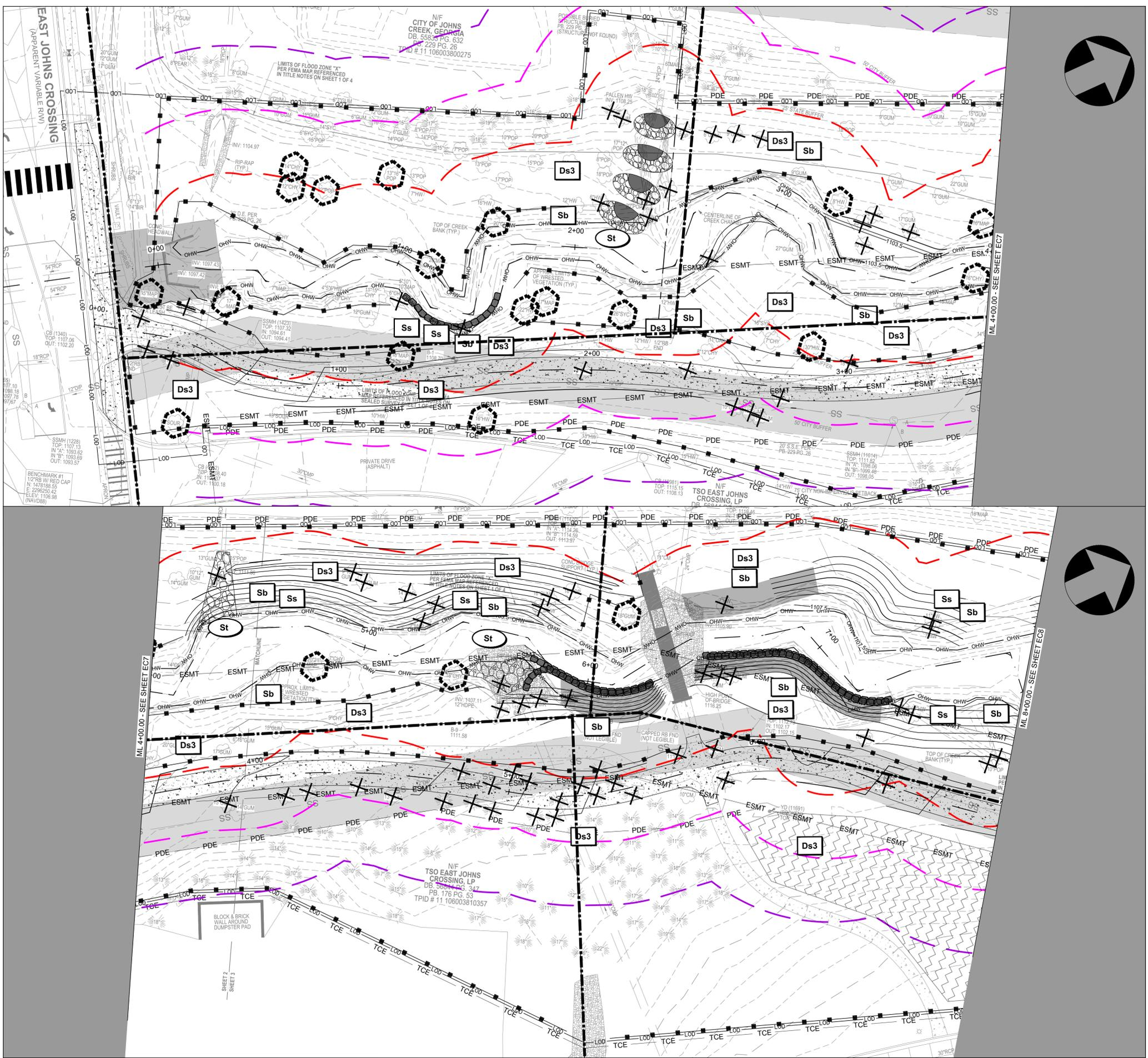

Received  
 Dec 7, 2023  
 V-23-0019  
 Planning & Zoning

**ADDITIONAL LEGEND**

- 25' STATE BUFFER
- 50' CITY BUFFER
- 75' CITY NON-IMPERVIOUS SETBACK
- LOD — LOD — LIMITS OF DISTURBANCE
- ■ — ■ — SEDIMENT FENCE (SILT FENCE)
- CONSTRUCTION STAGING AREA
- CONCRETE WASHOUT DEVICE
- TREE REMOVAL
- TREE PROTECTION

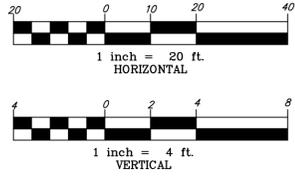

FILE PATH: Z:\Projects\2023\20230198.01.RA - TSD - Town Center Stream Restoration Design\CAD\Plan\_Sets\20230198.01\_EC\_PLAN.dwg, REE: 15/08/2023 11:27:14 AM



- PERMANENT STABILIZATION AND PLANTING NOTES:**
1. ALL SPECIES EVENLY DISTRIBUTED THROUGH PLANTING ZONES UNLESS OTHERWISE NOTED.
  2. DENSITY SHALL BE 544 PLANTS PER ACRE. SPACING SHALL BE 8' X 10' ON AVERAGE.
  3. PLANT MATERIAL SIZES ARE MINIMUMS.
  4. AREAS OUTSIDE PLANTING ZONES SHALL BE STABILIZED PER DETAIL Ds3, SHEET EC5.

- ZONE 1A**  
(SINGLE ROW PLANTED 2 FT FROM TOP OF BANK)
- |                 |                       |
|-----------------|-----------------------|
| 33% RIVER BIRCH | BETULA NIGRA          |
| 34% SYCAMORE    | PLATANUS OCCIDENTALIS |
| 33% RED MAPLE   | ACER RUBRUM           |

- ZONE 1B**  
(LANDWARD OF ZONE 1A ON CONSTRUCTED BENCHES)
- |                        |                       |
|------------------------|-----------------------|
| 20% EASTERN COTTONWOOD | POPULUS DELTOIDES     |
| 20% SYCAMORE           | PLATANUS OCCIDENTALIS |
| 15% RIVER BIRCH        | BETULA NIGRA          |
| 15% BOX ELDER          | ACER NEGUNDO          |
| 15% IRONWOOD           | CARPINUS CAROLINIA    |
| 5% SOUTHERN ARROWWOOD  | VIBURNUM DENTATUM     |
| 5% SPICEBUSH           | LINDERA BENZONI       |
| 5% RED CHOKEBERRY*     | ARONIA ARBUTIFOLIA    |
- \*PLANT IN TIGHTLY SPACED CLUMPS ON LANDWARD EDGE OF CONSTR. BENCHES

- ZONE 1C**  
(LANDWARD OF ZONE 1A TO 5 FT ABOVE TOP OF BANK WHERE NO BENCHES CONSTRUCTED)
- |                        |                         |
|------------------------|-------------------------|
| 22% EASTERN COTTONWOOD | POPULUS DELTOIDES       |
| 15% YELLOW POPLAR      | LERIODENDRON TULIPIFERA |
| 10% BOX ELDER          | ACER NEGUNDO            |
| 10% SYCAMORE           | PLATANUS OCCIDENTALIS   |
| 10% RED MAPLE          | ACER RUBRUM             |
| 10% IRONWOOD           | CARPINUS CAROLINIA      |
| 8% PERSIMMON           | DIOSPYROS VIRGINIANA    |
- \*PLANT IN GROUPS OF 5 TO 7 PLANTS
- |                       |                        |
|-----------------------|------------------------|
| 5% RED CHOKEBERRY*    | ARONIA ARBUTIFOLIA     |
| 5% SOUTHERN ARROWWOOD | VIBURNUM DENTATUM      |
| 5% PIEDMONT AZALEA    | RHODODENDRON CANESCENS |

- ZONE 2**  
(5 FT IN ELEVATION ABOVE TOP OF BANK TO 15 FT IN ELEVATION ABOVE TOP OF BANK)
- |                        |                          |
|------------------------|--------------------------|
| 10% EASTERN COTTONWOOD | POPULUS DELTOIDES        |
| 10% REDBUD             | CERCIS CANADENSIS        |
| 10% YELLOW POPLAR      | LERIODENDRON TULIPIFERA  |
| 10% SOUTHERN RED OAK   | QUERCUS FALCATA          |
| 10% NORTHERN RED OAK   | QUERCUS RUBRA            |
| 10% BLACK CHERRY       | FURNUS SEROTINA          |
| 10% AMERICAN HOLLY     | ILEX OPACA               |
| 10% PIEDMONT AZALEA    | RHODODENDRON CANESCENS   |
| 10% SWEET AZALEA       | RHODODENDRON ARBORESCENS |
| 10% OCOONEE AZALEA     | RHODODENDRON FLAMMEUM    |

**TOWN CENTER STREAM SPECIES LIST**

EASTERN COTTONWOOD	POPULUS DELTOIDES	24" BARE ROOT WHIPS OR TUBLINGS	1 GAL CONTAINER
SYCAMORE	PLATANUS OCCIDENTALIS	24" BARE ROOT WHIPS OR TUBLINGS	1 GAL CONTAINER
RIVER BIRCH	BETULA NIGRA	24" BARE ROOT WHIPS OR TUBLINGS	1 GAL CONTAINER
YELLOW POPLAR	LERIODENDRON TULIPIFERA	2.0 BARE ROOT OR TUBLINGS	1 GAL CONTAINER
BOX ELDER	ACER NEGUNDO	2.0 BARE ROOT OR TUBLINGS	1 GAL CONTAINER
SOUTHERN RED OAK	QUERCUS FALCATA	2.0 BARE ROOT OR TUBLINGS	1 GAL CONTAINER
NORTHERN RED OAK	Q. RUBRA	2.0 BARE ROOT OR TUBLINGS	1 GAL CONTAINER
WHITE OAK	Q. ALBA	2.0 BARE ROOT OR TUBLINGS	1 GAL CONTAINER
RED MAPLE	ACER RUBRUM	36" BARE ROOT WHIP	1 GAL CONTAINER
BLACK CHERRY	FURNUS SEROTINA	24" BARE ROOT WHIPS	1 GAL CONTAINER
AMERICAN HOLLY	ILEX OPACA	24" BARE ROOT WHIPS	1 GAL CONTAINER
IRONWOOD	CARPINUS CAROLINIA	24" BARE ROOT WHIPS	1 GAL CONTAINER
PERSIMMON	DIOSPYROS VIRGINIANA	24" BARE ROOT WHIPS	1 GAL CONTAINER
REDBUD	CERCIS CANADENSIS	24" BARE ROOT WHIPS	1 GAL CONTAINER
SOUTHERN ARROWWOOD	VIBURNUM DENTATUM	24" BARE ROOT WHIPS	1 GAL CONTAINER
SPICEBUSH	LINDERA BENZONI	24" BARE ROOT WHIPS	1 GAL CONTAINER
RED CHOKEBERRY	ARONIA ARBUTIFOLIA	24" BARE ROOT WHIPS	1 GAL CONTAINER
PIEDMONT AZALEA	RHODODENDRON CANESCENS	24" BARE ROOT WHIPS	1 GAL CONTAINER
SWEET AZALEA	RHODODENDRON ARBORESCENS	24" BARE ROOT WHIPS	1 GAL CONTAINER
OCOONEE AZALEA	RHODODENDRON FLAMMEUM	24" BARE ROOT WHIPS	1 GAL CONTAINER
FLORIDA AZALEA	RHODODENDRON AUSTRIANUM	24" BARE ROOT WHIPS	1 GAL CONTAINER

Received  
Dec 7, 2023  
V-23-0019  
Planning & Zoning

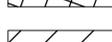
-  PLANTING ZONE 1A
-  PLANTING ZONE 1B
-  PLANTING ZONE 1C
-  PLANTING ZONE 2

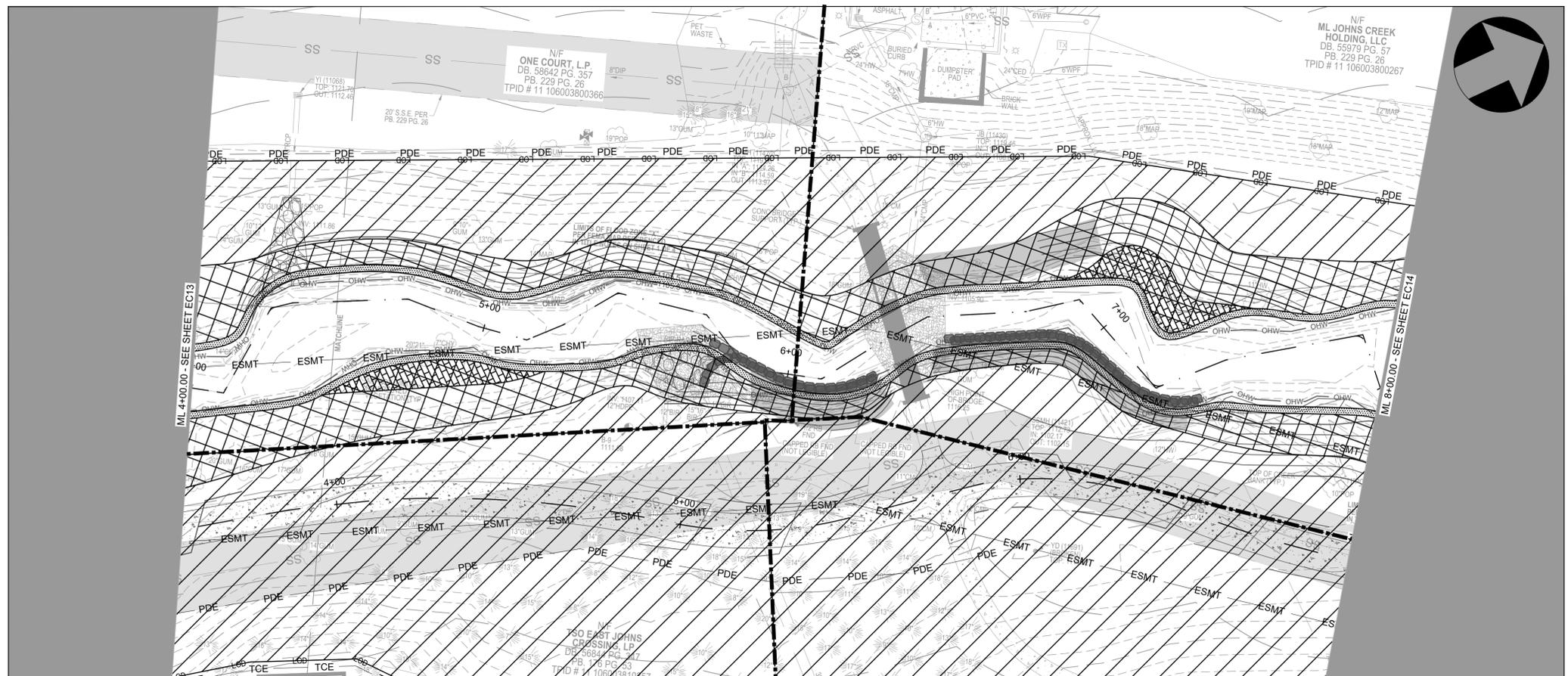
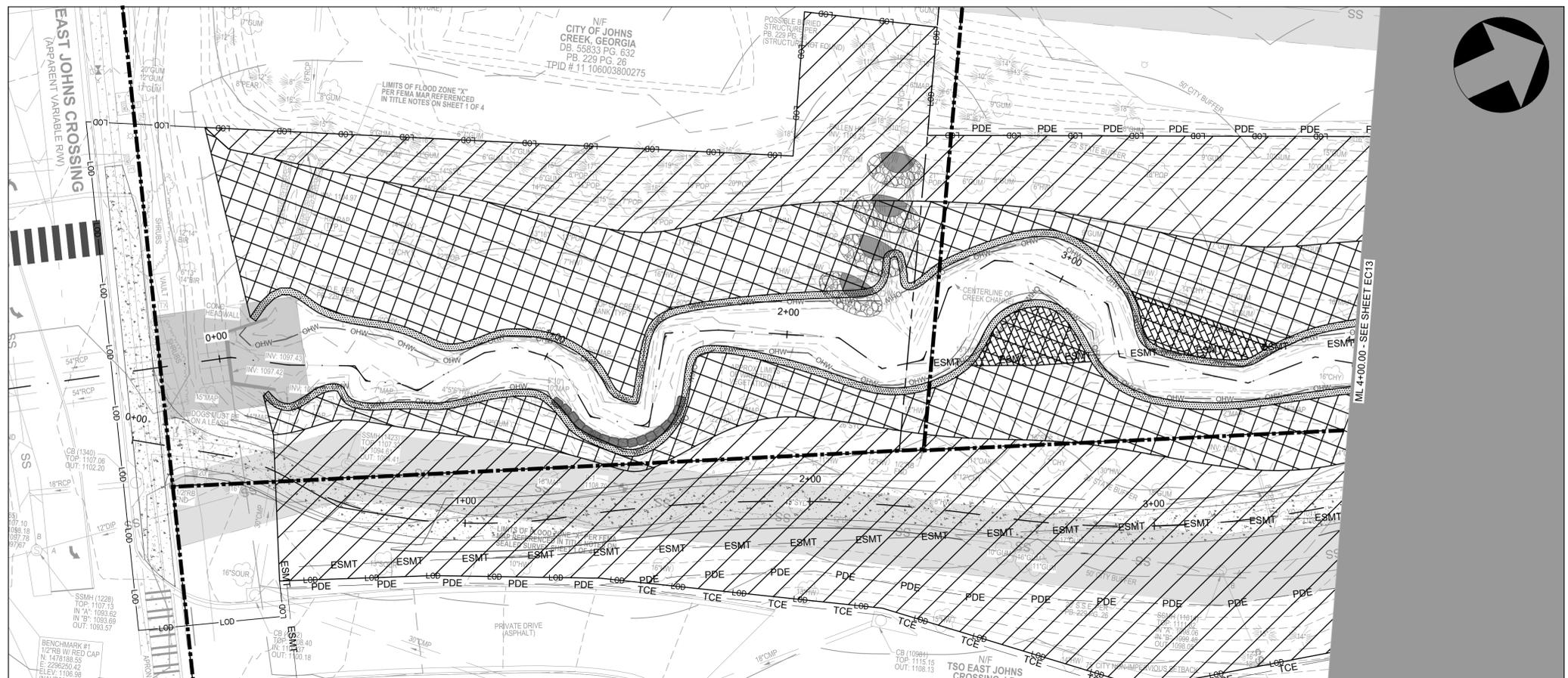
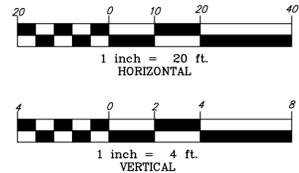

**WK DICKSON**  
community infrastructure consultants  
720 CORPORATE CENTER DR  
RALEIGH, NC 27607  
(919) 782-0495  
WWW.WKDICKSON.COM

GEORGIA  
W. K. DICKSON & COMPANY, INC.  
REGISTERED PROFESSIONAL ENGINEER  
EXPIRES 06/30/2024  
C.O.A.

PROFESSIONAL SEAL

NO.	DATE	DESCRIPTION

PROJECT NAME: TOWN CENTER STREAM RESTORATION DESIGN FOR CITY OF JOHNS CREEK  
DRAWING TITLE: PLANTING PLAN - STA 0+00 TO 8+00

PROJ. MGR.: TLM  
DESIGN BY: LD  
DRAWN BY: BFL  
PROJ. DATE: OCT. 2023  
DRAWING NUMBER: EC13  
WKD PROJ. NO.: 20230198.01.RA

PERMITTING SET - FOR REVIEW ONLY

